

NRDI COMOTI'S WIND TURBINE TECHNOLOGY KNOW-HOW TRANSFER

Vlad Alexandru Popa¹, Ion Mălăeș², Mihail Pușcaș Cernat³

^{1,2}National Research and Development Institute for Gas Turbines COMOTI, Department of Computational Gas, Dynamics, 220D Iuliu Maniu Blvd., District 6, 061126, Bucharest, Romania

³Topintechology Consult , 14 Cuza Vodă street , District Prahova, Sinaia, Romania

E-mail: Vlad Alexandru Popa, vladalexandru.popa@yahoo.com

Abstract: Knowledge transfer is a term used to describe a large number of activities that support joint undertakings between research institutes and private companies. Knowledge and technology transfer can be defined as the movement of knowledge and technology from an organization to another. The following paper will present NRDI COMOTI's procedure for knowledge transfer towards an industrial partner in the field of wind turbines. The partner is going to use the new knowledge to develop a competitive product. The procedure is structured in multiple stages, including the theoretical approach to early design in wind turbines, numerical analysis to determine the performances, the standards in issuing technical documentation, the FEM analysis to determine the values of stress and vibration, and finally, the manufacturing process. In the early design stage, conventional equations will be used to estimate the output power of the wind turbine. For the numerical analysis, CFD methods will be used to evaluate the performances. For technical documentation, this paper will present the various pieces of software used by COMOTI in the process of developing and manufacturing of wind turbines. The article will be concluded by a step by step manufacturing technology development process.

1. Introduction

In nowadays, knowledge is defined as being an intangible and subjective resource [1][2], but it also seems to be the most valuable resource in most organizations, due to the dynamics of economy and globalization [3]. The current business environment allows companies to be successful only if they have a competitive advantage, when it comes to their resource in knowledge[4]. As a consequence, rapid technological development of a company may be a great boost for productivity and creativity [5], making the process of knowledge transfer an invaluable asset for any organization.

Research and knowledge transfer is the process through which new technology and knowledge acquired in research institutes is made available for use to the private sector, with the purpose to increase the efficiency of services, to improve the products, to perfect the processes of manufacturing and the development of new products aimed at national and international markets. This collaboration intends to train the human resource of the industrial partner to develop their professional abilities in order to promote the results of research. The concept of technology transfer relies on an active process

¹ To whom any correspondence should be addressed.

of technology movement from one entity to another, having the purpose of sharing the results of research to a wider audience, which should materialize into new competitive products.

The purpose of this knowledge transfer procedure is to train and develop the personnel of the industrial partner in order to achieve the desired outcome in their respective field of interest. Technology transfer is generally perceived as a transfer of research results from institutes (universities, research institutes) towards the private sector or other components of society.

The transfer can take place under many forms. The mechanisms of technology transfer may include financial advising, patent transfer, personnel training etc. These forms of transfer can be either active, through direct training, or passive, by providing the technical documentation.

Lall [6] has noted that economic and industrial growth are directly related to the amount of efficient transfer of technology and knowledge from public institutions and the capacity of the private organizations to absorb it. However, the procedure of knowledge transfer is a very complex process [7], given the many limitations and barriers that hamper the successful transfer of knowledge or technology, the most notable is the human factor [8], the second barrier is the fact that there is still a difference between the knowledge produced by researchers, and the knowledge used in the industry[9]. It is of utmost importance to identify efficient ways of diffusion to ensure a good and full use of research results [10].

The chosen means of transfer are fully adaptable to meet the requirements of the industrial partner. The approach divided into stages wants to obtain a comprehensive and thorough dissemination of information, to ensure a worthwhile partnership.

The amount of knowledge disseminated to the public environment is a good way to evaluate the performance of a public institute [10], showing whether the research fields are relevant and in concordance with the needs of the society [11].

Our institute's initiative to transfer its know-how in wind turbines, comes as a response to the European trend of adopting renewable technologies to power the future. A fruitful collaboration would allow us to capitalize as much of Romania's wind potential as possible. The latest European norms want renewable energy to have a share of around 20% of the total energy produced, by 2020. Romania's wind potential is estimated to be around 14000 MW, which is the highest in continental Europe[13]. We are currently harvesting around 3000 MW through wind turbines, which leave around 11000 MW of wind power that can be converted into electricity.

The last decades have seen an increase in the interest of renewable energy technology, due to policies that encourage it and the threat of global warming and fossil fuels depletion [14]. Wind energy has the advantage of being the more viable and cost effective of the energy generation technologies, which makes it the go-to choice when it comes to developing a cleaner future.

Renewable energies have the benefit of being inexhaustible, giving them a great economic and environmental advantage over the conventional types of energies.

COMOTI's knowledge in developing wind turbines relies on a procedure, that goes through all the required steps in order to make a efficient and performant wind turbine. The following chapters will go through all these steps that are required in the research and development of a wind turbine.

2. Early design

The method employed for the early design step, relies on calculation that involves the momentum theory in a single stream tube. The calculation method used is semi-empirical, requiring the use of both analytical and experimental data (the drag and lift coefficients of the blade airfoil), in order to determine the torque and power output of the wind turbine. The first step in this method is to determine the angle of variation of the blades, θ_i , in the range of $0^\circ - 360^\circ$. For each value of θ_i , the following algorithm is executed:

i) As an engineering approximation, it is assumed that the velocity of the wind on the blade at the i step, V_i , is equal to the undisturbed upstream velocity of the wind U :

$$a_i = \frac{V_i}{U} = 1 \quad (1)$$

ii) The angle of incidence is computed:

$$\alpha_i = \arctan\left(\frac{V_i \cos \theta_i}{\lambda U - V_i \sin \theta_i}\right) + \alpha_0 \quad (2)$$

where α_0 is the angle of attack, and λ is the ratio between the tangential velocity of the blade and the undisturbed velocity of the wind, also known as Tip Speed Ratio – TSR):

$$\lambda = \frac{\omega R}{U} \quad (3)$$

iii) The absolute velocity is computed:

$$W_i = \sqrt{(V_i \cos \theta_i)^2 + (\lambda U - V_i \sin \theta_i)^2} \quad (4)$$

iv) The Reynolds number is calculated:

$$\text{Re}_i = \frac{W_i b}{\nu} \quad (5)$$

v) The coefficient of the normal force is calculated:

$$C_{n,i} = C_z(\alpha_i) \cos \alpha_i + C_x(\alpha_i) \sin \alpha_i \quad (6)$$

where C_x and C_z are determined as a function of the airfoil geometry and the angle of incidence.

vi) The function of the velocity losses coefficient is computed:

$$G(a) = \frac{Nb}{8\pi R |\cos \theta_i|} \left(C_{n,i} \cos \theta_i + C_{t,i} \sin \theta_i \right) \left(\frac{W_i}{V_i} \right)^2 \quad (7)$$

vii) The velocity losses coefficient is recomputed:

$$a = \frac{1}{1 + G(a)} \quad (8)$$

The algorithm above is reiterated until the desired accuracy is achieved. After which, the torque is computed for every value of θ_i :

$$T_i = \frac{\rho R W_i^2 b C_t h}{2} \quad (9)$$

Every value of the torque at each i step of the blade is summed up, resulting the torque output of the wind turbine for a full rotation. The mean value of the sum, is the mean torque output of the turbine. The mean power output is computed using the following equation:

$$P = \omega T \quad (10)$$

Finally, if the power of the wind stream is:

$$P_w = \rho R h U^3 \quad (11)$$

the efficiency of the turbine is calculated using:

$$C_p = \frac{P}{P_w} \quad (12)$$

3. Numerical evaluation of the performances of the wind turbine

In order to determine the velocity and pressure field in the rotor, and to predict the performances of the wind turbine. the equations of conservation are being employed, with the use of Computational Fluid Dynamics (CFD).

Unlike traditional methods of assessing the efficiency of a wind turbine, the numerical evaluation has the advantage of being both inexpensive, and gives complete data about the turbine (velocities, pressure distribution, temperatures etc.). This level of data is close to impossible to obtain in experimental testing of wind turbines, from a practical standpoint.

The movement of a flow is governed by a set of equations, known as the Navier-Stokes equations, presented below in their general, non-steady, compressible form, using tensorial notations:

$$\frac{\partial \rho}{\partial t} + \frac{\partial \rho u_i}{\partial x_i} = 0 \quad (13)$$

$$\frac{\partial \rho u_i}{\partial t} + \frac{\partial}{\partial x_j} (\rho u_i u_j + p \delta_{ij} - \tau_{ji}) = 0 \quad (14)$$

$$\frac{\partial \rho E}{\partial t} + \frac{\partial}{\partial x_j} [(\rho E + p) u_j + q_j - u_j \tau_{ij}] = 0 \quad (15)$$

In these equations, the following variables are defined:

The tensor of the viscosity effort:

$$\tau_{ij} = \mu \left(\frac{\partial u_i}{\partial x_j} + \frac{\partial u_j}{\partial x_i} \right) - \frac{2}{3} \mu \frac{\partial u_k}{\partial x_k} \delta_{ij} \quad (16)$$

The total specific energy:

$$E = e + \frac{1}{2} u_k u_k \quad (17)$$

The internal specific energy:

$$e = h - \frac{p}{\rho} \quad (18)$$

At this step of the knowledge transfer process, the appropriate setup of a flow analysis case is shown, using the CFD software, ANSYS Fluent. At first, the computational domain is divided in two subdomains, the rotor, which includes the blades and the shaft of the turbine, and the stator, which represents the environment. The grid was generated using specialized software that produces the adequate mesh for the case. The main parameters used to generate the grid, are the value of y^+ , and the growth ratio, which help simulate the flow in the boundary layer. Smoothing functions for the grid can be applied, in order to control the growth ratio between separate blocks, and insure fine transition between cells. In Figure 1 a grid for a CFD simulation of a vertical axis wind turbine is presented.

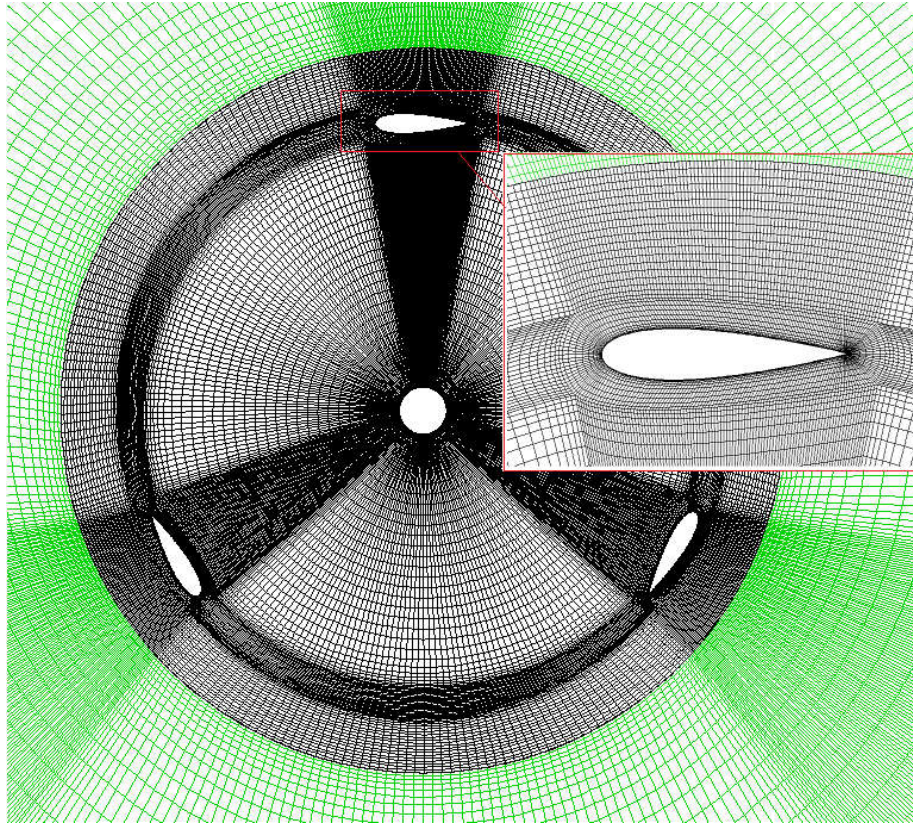

Figure 1: The grid

Table 1 shows the necessary setting required by ANSYS Fluent for a case.

Table 1. Case setting for the ANSYS-Fluent solver				
	Solver	Pressure Based	Unsteady	2D
Models	Viscous Model	k- ω SST		
Materials	Air	Density, constant		
Operating conditions	Pressure	101325[Pa]		
Boundary Condition	Inlet	Velocity inlet $V_x=7\text{m/s}$		
	Pale	wall		
	Shaft	wall		
	Interface	Interface rotor-stator		
	Rotor	Mesh motion		
	Stator	Stationary		
Solve	Controls	Solution	Courant nr=2	Discretization 2 nd order upwind
	Initialization	Inlet		
	Monitors	Residuals	10^{-6}	
	Iterate	Force	Torque coefficient	
Report		10^6 Steps	0.001s time step size	
	Reference values	Inlet	Length=radius of the turbine	

The boundary conditions are chosen in such a manner to simulate the flow as closely as possible to the real phenomenon. As chosen results, the variation of the torque coefficient over a period of $T=360^\circ$, was chosen.

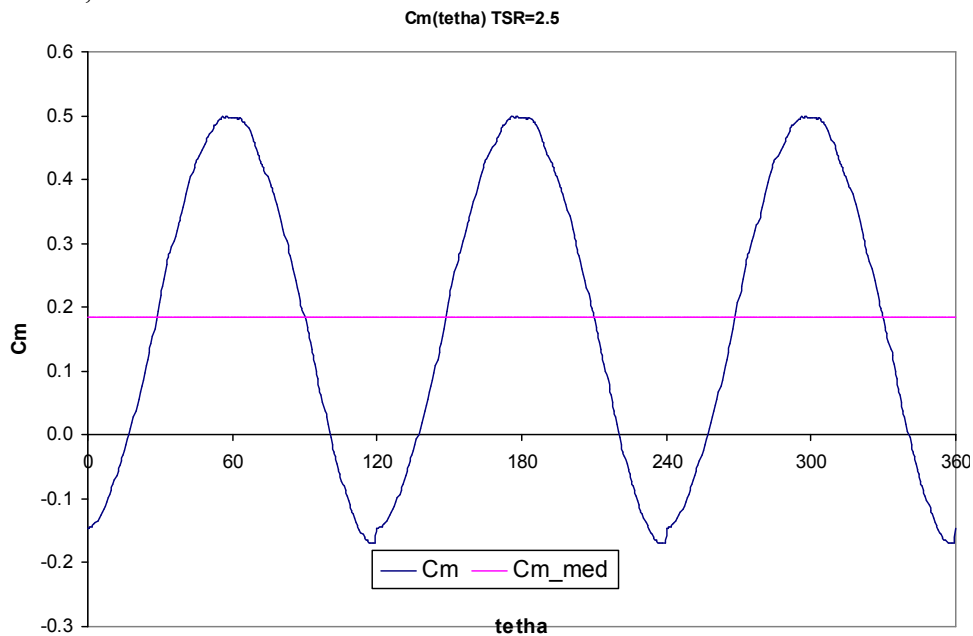

Figure 2.The variation of the torque coefficient at TSR=2.5

Using the mean value of the torque coefficient generated by the CFD analysis, along with the theory, the power coefficient can be plotted as a function of TSR. Figure 3 shows this variation of the power coefficient, but it also shows that at values lower than 1 of the TSR, the C_p values are very low, implying that the wind turbine finds itself in stall.

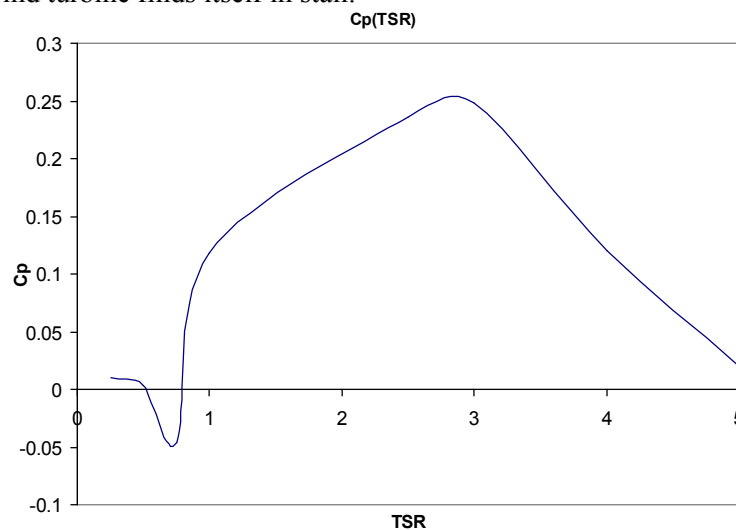

Figure 3.The variation of the power coefficient

To better understand the phenomenon that takes place inside the rotor, the streamlines can be plotted for different positions of the blades. Figure 4 shows the streamlines for different at different positions to allow a better understanding of the flow around the blades.

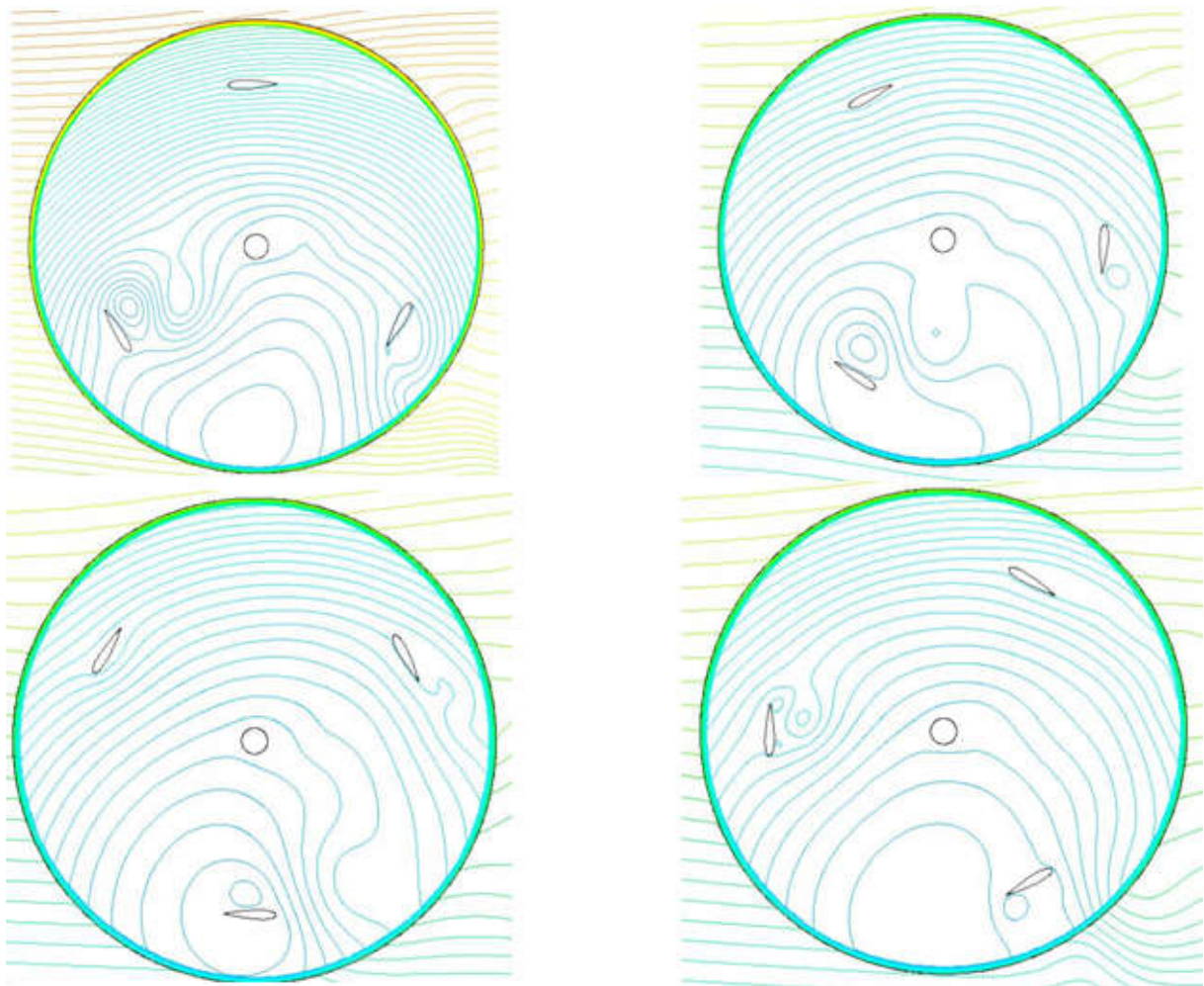
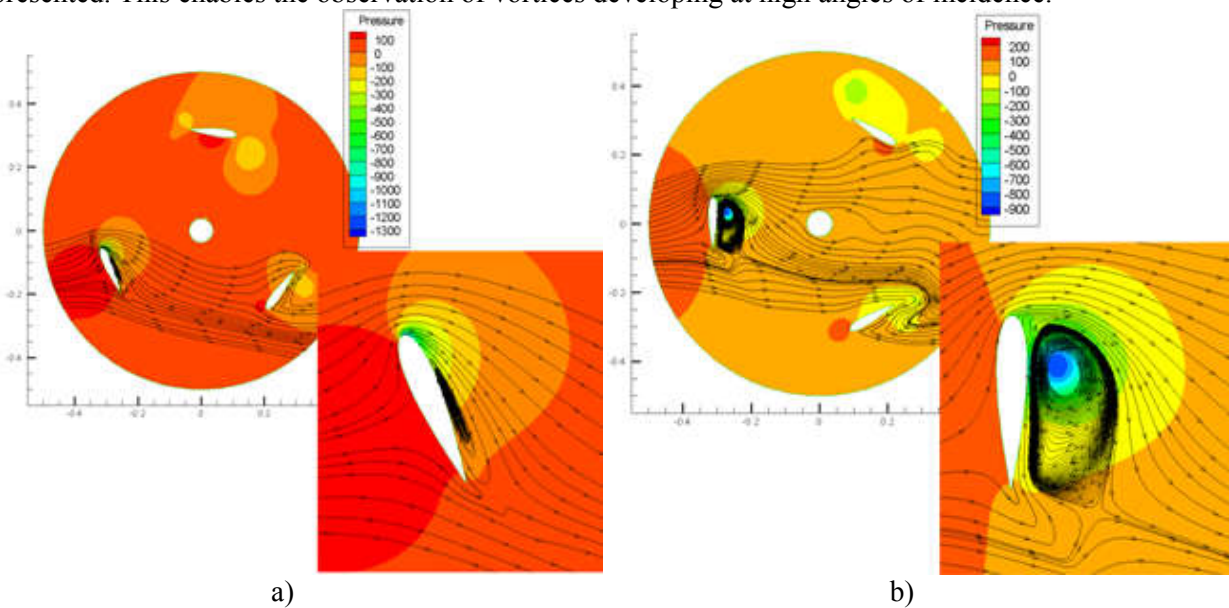

Figure 4. Streamlines for a three-bladed vertical axis wind turbine

In Figure 5 the flow around the blades of the wind turbine at different angles of incidence is presented. This enables the observation of vortices developing at high angles of incidence.



a)

b)

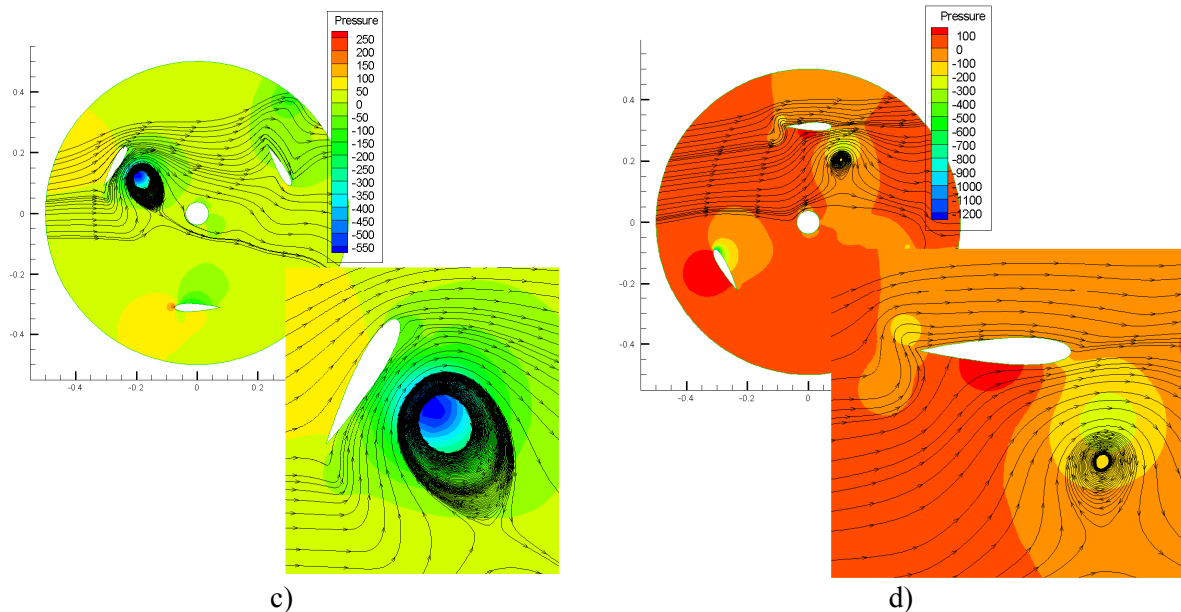

Figure 5.Streamlines for : a) $\theta = 60^\circ$, b) $\theta = 90^\circ$, c) $\theta = 120^\circ$, d) $\theta = 180^\circ$

4. Issuing technical documentation

The process of designing is an iterative one, formed over multiple steps that may require slight changes, depending on the type of the project. Some of the steps are:

- needs analysis: an analysis that shows the necessity to develop a new product or the use of a currently available one.
- problem definition: it shows the input data for the project, and the requirements (i.e. physical and functional characteristics, performance of the product, etc).
- analysis and synthesis: it is an iterative process through which a product/subsystem/part of a system is designed by the draftsman, undergoes a technical analysis, and redesigned in order to be improved to the point where it meets the requirements of the project.
- evaluation: takes place by assessing the degree of fulfillment of the initial requirements imposed during the problem definition phase. At this step, manufacturing a scale model and testing it may be required, in order to obtain data regarding its performances, quality and other criteria.
- presentation: refers to the technical documentation that is required to manufacture the product (drawing, tally sheet, material specifications, etc.), this being the last step of the project.

The computer aided process of design does not differ from the conventional design process, the only exception is the categorization of steps:

- a. needs analysis;
- b. problem evaluation/definition;

The technical documentation is based on designing the shaft, the support structure of the wind turbine. The first step in the making of the wind turbine, is the drawing of the 3D model, using a CAD software. In designing parts, certain standards have to followed in order to optimize the cost and resources necessary to make the whole assembly:

- SR EN 1091-1 regarding the choice of flange for the support shaft;
- SR EN ISO 4017:2002, SR 7666-2:1994, SR EN ISO 7089:2002 and SR EN ISO 4035:2003 regarding the parts necessary for the turbine and the supporting shaft;
- BS EN 10210-2:2006 – to choose the type of the pipe and its dimensions;
- DIN EN 22553, SR EN 13480-5 – regarding the inspection and testing of the welds.

In general, a wind turbine has 5 main components: polepost, supporting shaft (which incorporates the anchor section of the turbine), generator, shaft and the rotor along with the blades, support bars and the bearing system. All these components are presented and explained in Figure 6.

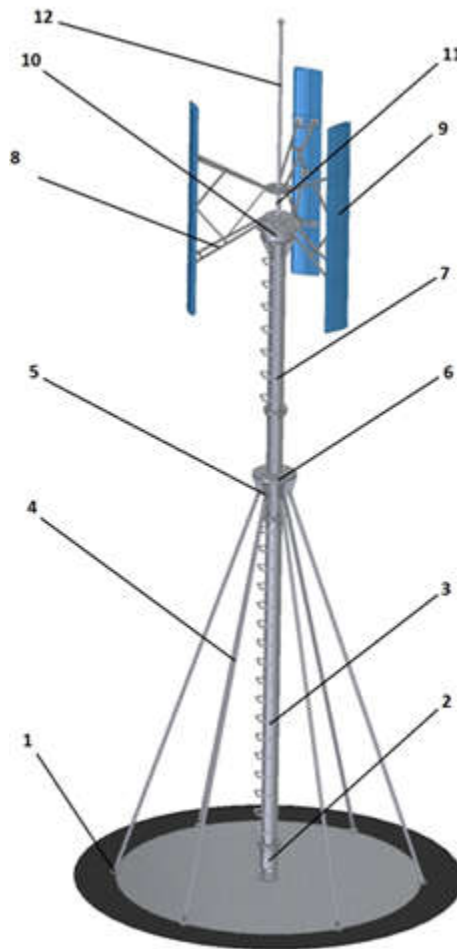

Figure6.3D model of the wind turbine: 1 – base supporting flange; 2 – pole post; 3 – section I; 4 – anchor bar; 5 – support hold on the shaft/anchor flange; 6 – anchor section; 7 – section II; 8 – hold bars for blades; 9 –NACA type blades; 10 – generator case; 11 – bearing system and the blade holding system; 12 – lightning discharger.

5. Finite Element Analysis (FEA)

To evaluate the mechanical strength of the assembly, it is recommended to study the maximum load on the turbine, corresponding to a wind velocity of 40 m/s.

To conduct the finite element analysis, the following input data should be considered:

- a. Material properties: steel for the shaft and bushings; pre-peg HexPly for the airfoil and ribs;
- b. Maximum wind velocity: 40 m/s;
- c. Turbine geometry;
- d. Airfoil and span structure;
- e. Finite element model.

Material properties are presented in the following table:

Table2. Material properties

Name	Steel	HexPly
Elastic modulus, E [GPa]	205	E11=E22=62.3
Poisson's ratio, ν	0.28	0.28
Density, ρ [kg/mc]	7860	1472

Figure 7 presents the finite element method, applied on a vertical axis wind turbine:

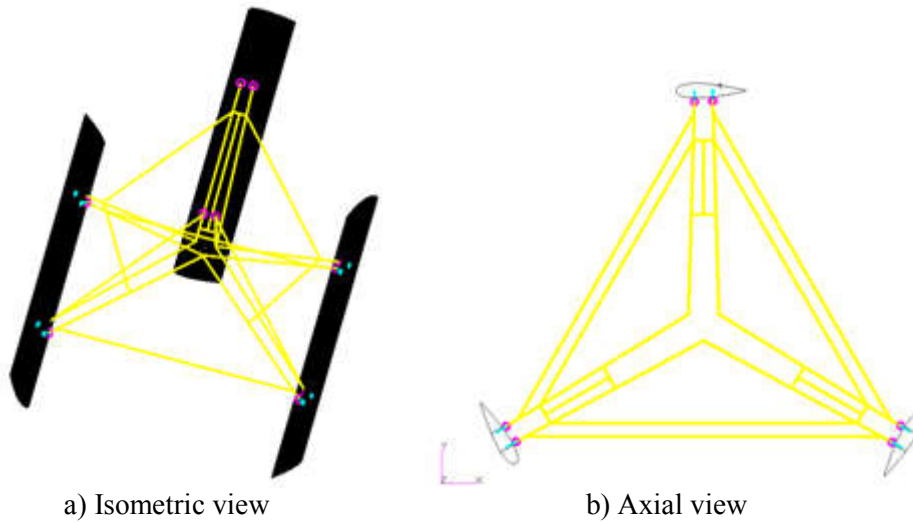

Figure 7. The finite element method

The model is formed of shell type elements to model the airfoil and the spans, bar type elements to model the shaft, and hexa elements to model the bushings.

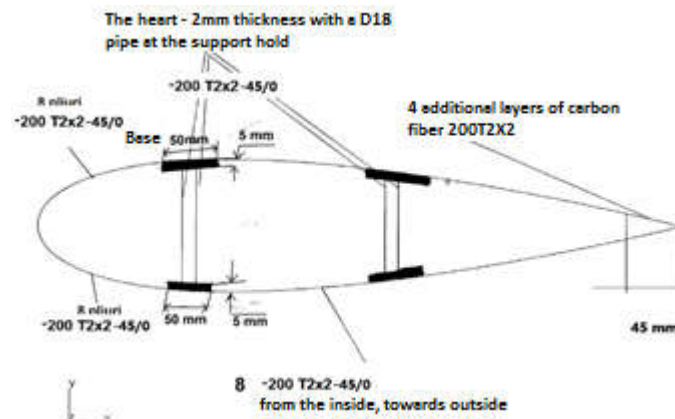
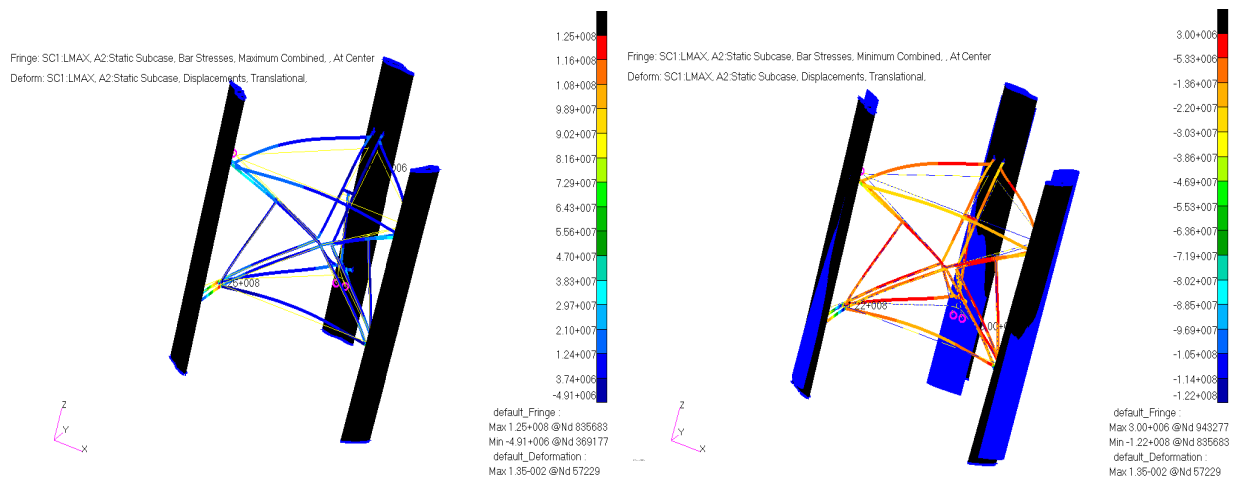

Figure 8. Laminar structure of the blade-span assembly

Under the load, at wind velocity of 40 m/s, the maximum displacement is determined, and its location on the trailing edge of the blade situated perpendicular to the wind stream. The evaluation of the composite material is done using the maximum value of the main stress and the maximum value of the shear stress, presented in the following figures.

The evaluation of the stress and vibration analysis relies on determining the maximum main stress on the laminar layers, and the breaking point through traction/compression, maximum shear stress and the breaking point through interlayer shear, the maximum stress corresponding to a factor of safety, the maximum Von Mises stress corresponding to a factor of safety, and the Eigen modes.



a) the stress in the supporting system (system of bars) – maximum [Pa]

b) the stress in the supporting system (system of bars) – minimum [Pa]

Figure 9. The maximum stress on the supporting structure [Pa]

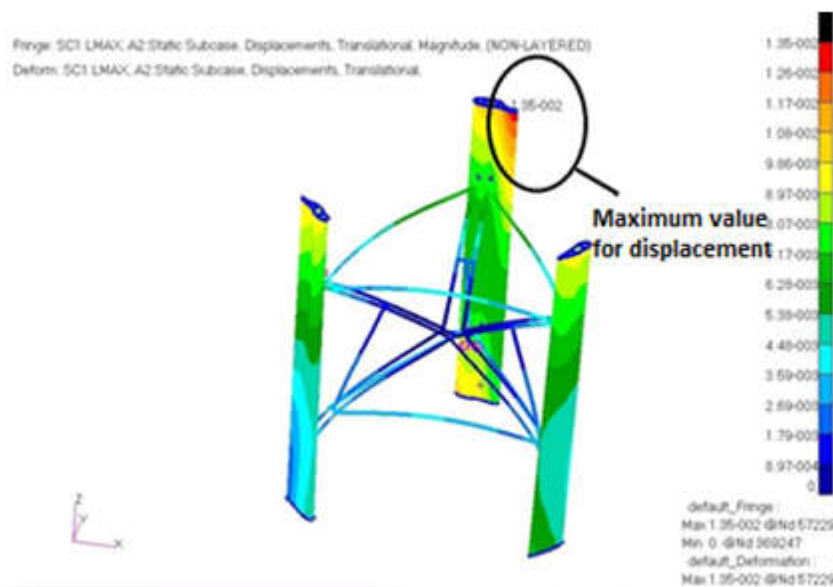

Figure 10. The distribution of the displacements [m]

6. The technological process of making the blades out of composites

To start the technological process of blade fabrication from composite materials requires a mold made of two components, which are defined by the separation plane. The process of blade fabrication starts with a layer a of carbon fiber with an ascending offset on a semi-mold, with the longest layer of carbon fiber towards the mold, and bent at the trailing and leading edge. Over the layers of prepreg, a release film is placed with the vacuum bag (Figure 11). On the side, mastic tape is placed, and then the other edge is folded over the mastic tape that is placed on the back end. At the ends of the inner vacuum bag, mastic tape is used to make the connection to the outer vacuum bag. On the second semi-mold, 8 layers with descending offset are placed, with the longest layer towards the mold, and also containing a layer of release film.

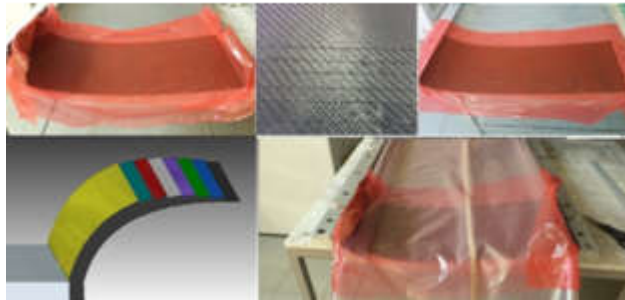

Figure 11.Placing the layers of prepeg, the release film and the inner vacuum bag

After making the assembly for the autoclave, the vacuum lines are connected (Figure 12). After insuring that there are no imperfections on the assembly or any are where the mastic was not properly taped, the cycle of polymerization can begin. After removing the mold, it can be observed, whether or not the surface has any defects on the suction or pressure side (Figure 13).



Figure 12.Vacuuming the mold

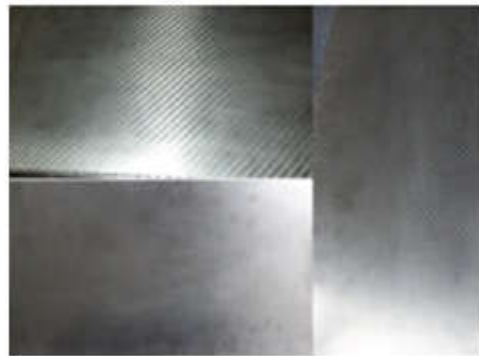

Figure 13. The surface of the airfoil after removing the mold

A technological test of making a section of the span at the leading edge has been implemented, and for this test fine glass fiber has been integrated in wind turbine blades and it is shown in the following figures.



a)



b)



c)

Figure 14. a) demarcation și b) cutting of the fine layers of glass fiber; c) welding of the Ø18 mm pipe, with the 2 metal plates



Figure 15.Joining the components that form the span section in the leading edge



Figure 16.The airfoils after removing them from the mold

7. Conclusions

In this scientific paper, the procedure of making wind turbines used by NRD Comoti has been presented. With this procedure, the process of knowledge transfer from the institute to an industrial partner can take place, in order to develop a competitive product. This procedure relies on the theoretical approach in early design of wind turbines and advises the use of CFD methods to estimate the aerodynamic performance of the wind turbine. The making of the technical documentation is an extremely important step in which the strength of the components and the strength of the bearing system are defined, with regard to the standards. To make the 3D model and the drawings of the assembly, CAD software are employed. The finite element analysis to determine the mechanical strength and the vibrations is essential in determining the behavior of the wind turbine under load. The manufacturing process relies on composite materials to fabricate the blades for the wind turbine. This paper also shows the necessary steps required to fabricate components out of composite materials.

8. Acknowledgement

This work was carried out within POC - Competitiveness Operational Program, supported by the EU and Romanian Minister of Research and Innovation funds, project number POC 9/01.09.2016, MySmsis 105890, ID P_40_309.

9. References

- [1] Carrillo P, Chinowsky P, 2006, *Exploiting knowledge management: the engineering and construction perspective*, Journal of Management in Engineering; 22(1): 2-10
- [2] Chen CJ, 2006, *The effects of knowledge attitude, alliance characteristics, and absorptive capacity on knowledge transfer performance*, R&D Management
- [3] Flor de la Cruz Salaiza, Lizarraga, Lina Marcela, Diaz Santamaria, Luis Alfredo, Vega Osuna, Pavel Anselmo Alvarez Carrillo, Rogelio Quijano 2013 *The knowledge transfer in educative institutions: a local study* (Eureka-2013. Fourth International Workshop Proceedings)
- [4] Balzhan Orazbayeva, Thomas Baaken, Arno Meerman 2016 *Intercultural Knowledge Transfer in Teams – Findings Based on a case Study* (The 20th World Multi-Conference on Systemics, Cybernetics and Informatics, Orlando, Florida, USA, Vol. II)
- [5] L Argote, P Ingram, 2000, *Knowledge transfer: a basis for a competitive advantage in firms*, Organizational Behavior and Human Decision Processes, Vol. 82, No. 1, pp. 150-169
- [6] Lall S, Weiss J, Zhang J, 1985-98, *The technological structure and performance of developing country manufactured exports*. Oxf. Dev. Stud. 28, 337-369
- [7] M Javidan, GK Stahl, FBrodbeck, CPM Wilderom, 2005, *Cross-border transfer of knowledge: cultural lessons from project GLOBE*, Academy of Management Executive, Vol. 1, No. 2, pp. 59-76.
- [8] Jung W, 1980, *Barriers to technology transfer and their elimination*. Journal of Technology Transfer; 4(2):15-25
- [9] von Storch H, Emeis K, Meinke I, Kannen A, Matthias V, Ratter B M, Stanev E, Weisse R, and Wirtz K, 2015: *Making coastal research useful – cases from practice*, Oceanologia, 57, 3-16
- [10] Chen CbJ, Hsiao YbC, Chu MbA, 2014, *Transfer mechanism and knowledge transfer. The cooperative competency perspective*, Journal of Business Research; 67(12):2531-2541
- [11] Arnott JC, Moser SC, and Goodrich KA, 2016: *Evaluation that counts: A review of climate change adaptation indicators & metrics using lessons from effective evaluation and science-practice interaction*, Environ. Sci. Policy, 66, 383-392
- [12] Renate Treffeisen, Klaus Grosfeld, and Franziska Kuhlmann, 2017, *Deriving evaluation indicators for knowledge transfer and dialogue processes in the context of climate research*, Advances in Science and Research, 14, 313-322
- [13] EWEA (February 2014). *"Wind in power: 2013 European statistics"*. European Wind Energy Association. Retrieved 2014-11-05.
- [14] Masoud Ghasemian, Najafian, Ashrafi Ahmad Sedaghat 2017 *A review on computational fluid dynamic simulation techniques for Darrieus vertical axis wind turbines* (Energy Conversion and Management vol. 149)